

Fawic FL30

Motorsport Freight Containers

Practical freight containers for motorsport spares, tools and support equipment.



Built for motorsport logistics

- Two clear standard options for quick budgeting.
- Built around real handling: forklift movement, loading clearance and repeat transport.
- Designed for land, sea and air logistics where required.
- Custom dimensions remains available when the standard solution does not fit.



Type	Optimized for	Description	Pricing
FL30 LSA	Air Freight	Chamfered-profile container optimized for airfreight with door portal and rolling bottom frame included	Competitive pricing, contact us for a quote
FL30 LS	Sea freight	Optimized sea freight container with door portal and rolling bottom frame included	Competitive pricing, contact us for a quote

Fawic FL30 container options

Fawic FL30 LSA – Land / Sea / Air

Chamfered-profile freight container for motorsport equipment requiring airfreight compatibility.

- Land / Sea / Air
- 2800 mm standard length (customizable)
- Door portal included (customizable)
- Rolling bottom frame included
- Aircraft profile configurable 747 / 777F / TDC

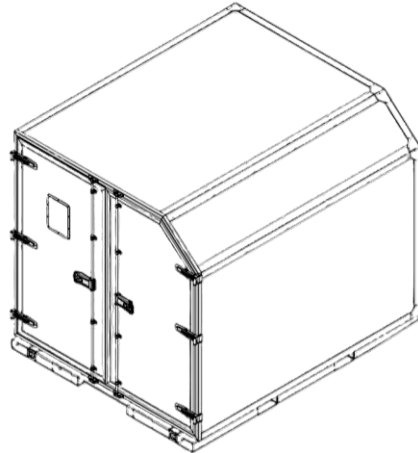

Fawic FL30 LS - Land / Sea

Optimized freight container for bulk transport of motorsport spares, tools and support equipment.

- Land / Sea optimized
- Dimensions optimized for sea freight containers
- Door portal included (customizable)
- Rolling bottom frame included
- Custom dimensions possible

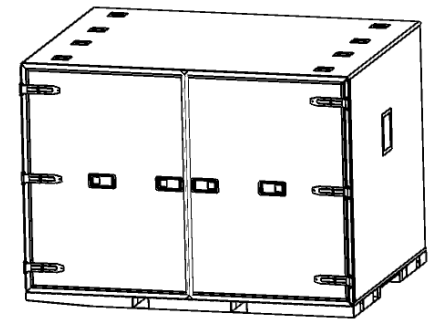

Custom bottom frame

Fawic FL30 containers include a practical bottom frame designed for repeat freight handling.

The container body is supported by an integrated bottom frame with rollers on one side, making the unit easier to position, load and handle during motorsport freight operations.

- Comparable handling concept to established motorsport shack systems.
- Rollers on one side for controlled movement during loading and positioning.
- Built into both standard options.
- Final roller layout, frame profile and forklift interface can be changed.



Fawic FL30 LSA – Land / Sea / Air

Chamfered-profile freight container for motorsport equipment requiring flexible freight modes.

A practical freight container for teams that need one standard solution for road, sea and selected airfreight movements.

- Chamfered upper section adaptable to selected aircraft loading profiles and ULD's.
- Designed to support 747 and 777F or to be determined.
- Standard 2800 mm length to allow four units lengthwise in a 40FT sea container.
- Door portal / personnel access door included in the standard price.
- Integrated bottom frame with rollers for easier handling.

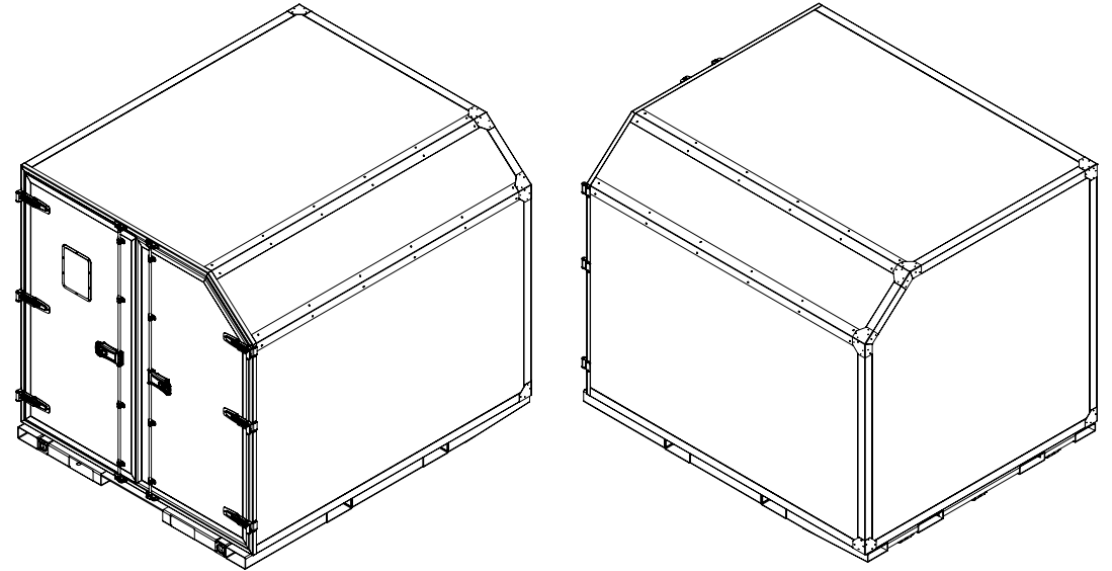

Fawic FL30 LSA – Land / Sea / Air

- Polypropylene honeycomb core panels
- Lightweight construction
- 30 mm panel system
- Repairable
- Standard length 2800mm, designed to allow 4 units to be loaded lengthwise in a 40FT container
- Dimensions customizable
- Integrated bottom frame with rollers
- Topboxes available upon request
- Angled roof for 747 / 777F / Other airliners
- Airlinetracks, internal compartments and other options available

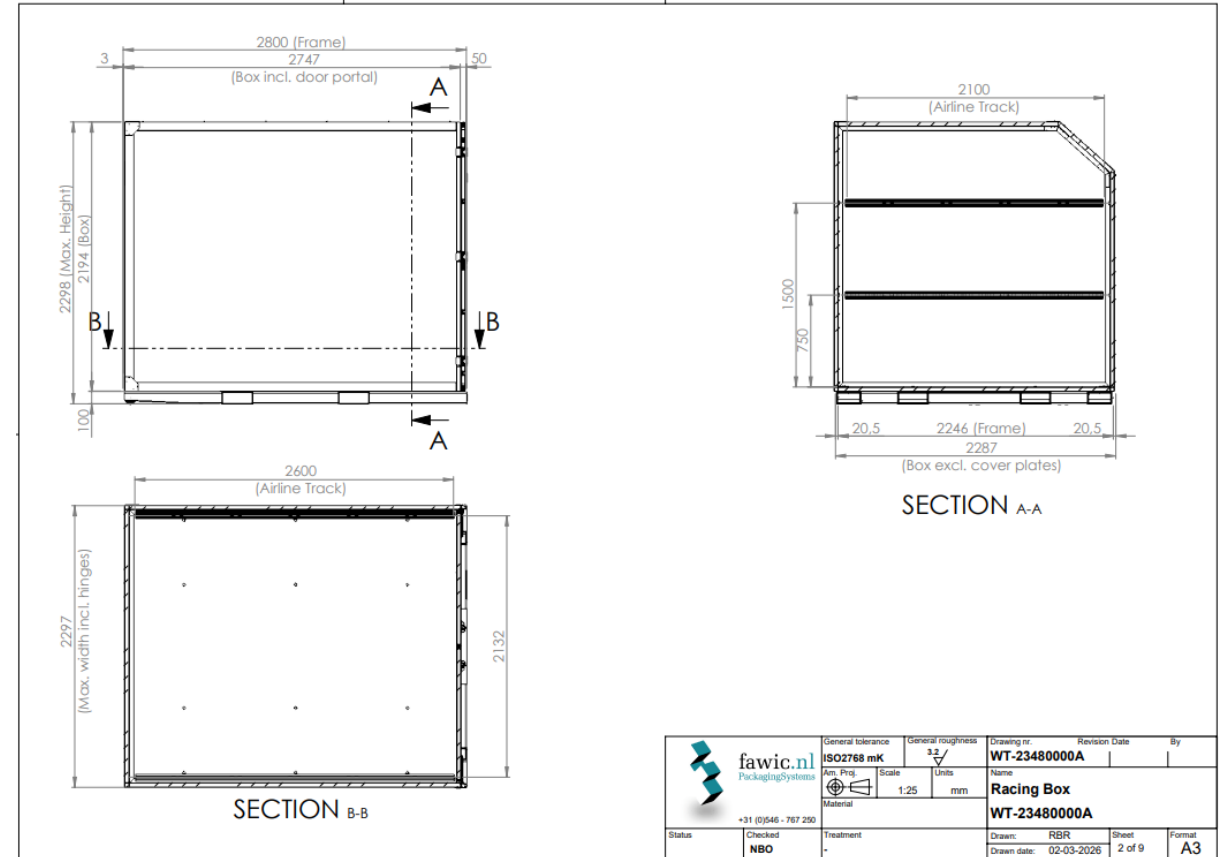

Fawic FL30 LS - Land / Sea Freight

For spares, tools and support equipment that need robust bulk transport, not a paddock workshop or office setup.

- Optimized around container loading: length, height, clearance and usable volume.
- Same Fawic FL30 construction principle and rolling bottom frame as the Air / Sea / Land version.
- Intended for spares, tools and bulk support equipment.
- Dimensions can be adapted when required by customer or logistics route.

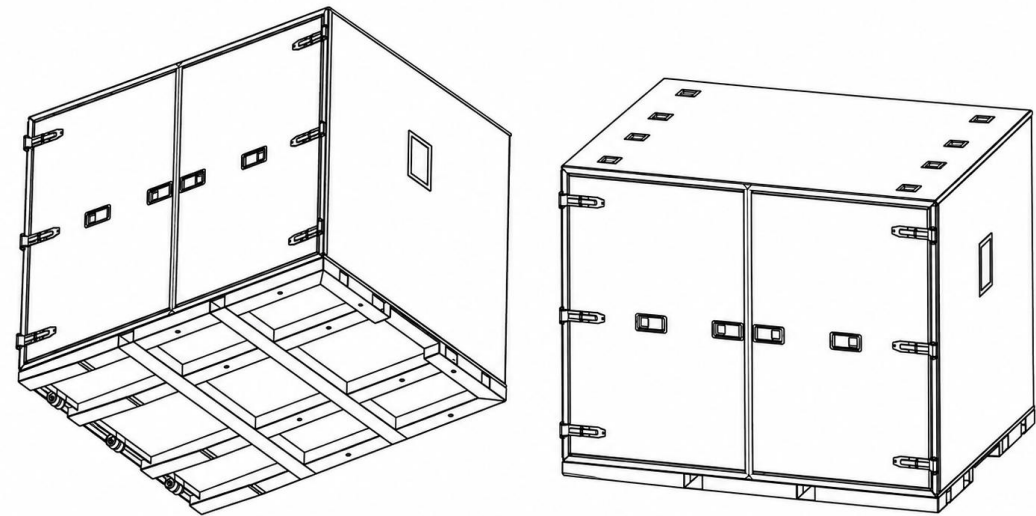

Fawic FL30 LS - Land / Sea Freight

- Polypropylene honeycomb core panels
- Lightweight construction
- 30 mm panel system
- Repairable
- Designed to be loaded efficiently in sea container and not waste space
- Dimensions customizable
- Integrated bottom frame with rollers
- Airlinetracks and other options available

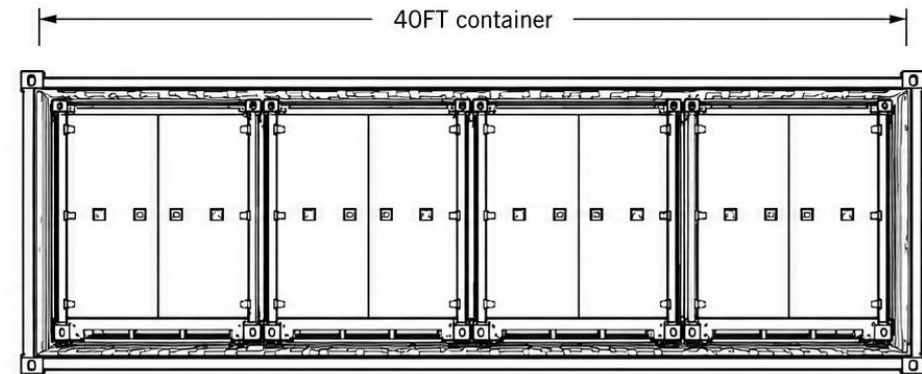

Optional features

Container / handling options

- Rectangular topbox
- Chamfered / triangular topbox
- Custom external dimensions
- Bottom frame variations / roller layout
- Forklift pockets or handling system
- Repairable
- Branding and topcovers

Fawic Packaging Systems designs and manufactures reusable transport, storage and handling solutions for demanding applications.

- ▶ Fawic B.V.
- ▶ Twentepoort West 49
- ▶ 7609 RD Almelo

- ▶ Tel. : 0546 767 250
- ▶ Mail: Info@fawic.nl